

R75PD1680DQ40J

Aliases (75PD1680DQ40J)

R75, Film, Metallized Polypropylene, Automotive Grade, 6,800 pF, 5%, 630 VDC, 85°C, 7.5 mm

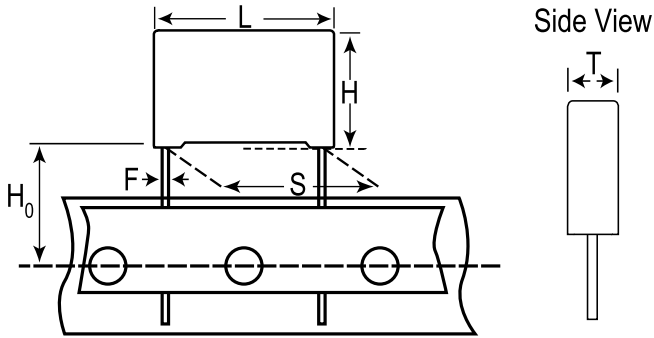

Click [here](#) for the 3D model.

General Information

Series	R75
Dielectric	Metallized Polypropylene
Style	Radial
Features	Automotive Grade, Pulse
RoHS	Yes
Termination	Tinned Wire
Lead	Wire Leads
Qualifications	AEC-Q200
AEC-Q200	Yes
Typical Component Weight	0.695 g
Miscellaneous	Above 85C DC And AC Voltage Derating Is 1.25%/C.

Specifications

Capacitance	6,800 pF
Tolerance	5%
Voltage DC	630 VDC
Voltage AC	250 VAC
Temperature Range	-55/+105°C
Rated Temperature	85°C
Dissipation Factor	0.04% 1kHz, 0.06% 10kHz, 0.25% 100kHz
Insulation Resistance	100 GOhms
Max dV/dt	2,400 V/us
ESR	117 mOhms (100kHz)
Ripple Current	1.07 Amps (100kHz 85C), 16 Amps (Peak)
Inductance	8 nH

Dimensions

L	10mm +0.2/-0.5mm
H	9mm +0.1/-0.5mm
T	4mm +0.1/-0.5mm
S	7.5mm +/-0.4mm
H0	18.5mm +/-0.5mm
F	0.5mm +/-0.05mm

Packaging Specifications

Packaging	Ammo, 360x340x59mm, Box
Packaging Quantity	2100

Statements of suitability for certain applications are based on our knowledge of typical operating conditions for such applications, but are not intended to constitute - and we specifically disclaim - any warranty concerning suitability for a specific customer application or use. This Information is intended for use only by customers who have the requisite experience and capability to determine the correct products for their application. Any technical advice inferred from this Information or otherwise provided by us with reference to the use of our products is given gratis, and we assume no obligation or liability for the advice given or results obtained.