

CWR11JB685MP

Aliases (CWR11JB685MP)

T492 CWR11, Tantalum, MnO2 Tantalum, Military/High Reliability, 6.8 uF, 20%, 20 VDC, SMD, MnO2, Molded, Military Equivalent, P (0.1%/1000 Hrs), 2.4 Ohms, 6032, 2.8mm

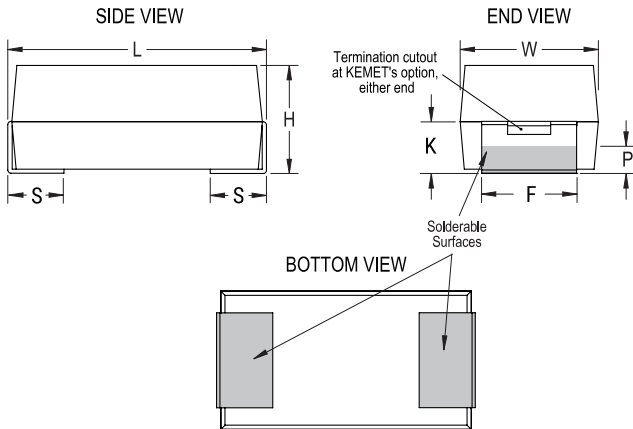

Click [here](#) for the 3D model.

General Information

Series	T492 CWR11
Dielectric	MnO2 Tantalum
Style	SMD Chip
Description	SMD, MnO2, Molded, Military Equivalent
RoHS	Yes
Termination	Gold
Qualifications	MIL-PRF-55365/8, CWR11 Style
AEC-Q200	No
Typical Component Weight	224.2 mg
Notes	Note: When Option C Is Selected For Lead Material, Add An Additional 0.38mm To The Tolerances For "L", "W", "H", "K", "F" And "S".
MSL	1

Dimensions

Footprint	6032
L	6mm +/-0.3mm
W	3.2mm +/-0.3mm
H	2.5mm +/-0.3mm
T	0.13mm REF
S	1.3mm +/-0.3mm
F	2.2mm +/-0.1mm
B	0.5mm +/-0.15mm
E	2.4mm REF
G	2.8mm REF
K	1mm MIN
P	0.5mm MIN
R	1mm REF
X	0.1mm +/-0.1mm REF

Packaging Specifications

Packaging	T&R, 178mm
Packaging Quantity	500

Specifications

Capacitance	6.8 uF
Capacitance Tolerance	20%
Voltage DC	20 VDC (85C), 13.4 VDC (125C)
Temperature Range	-55/+125°C
Rated Temperature	85°C
Dissipation Factor	6% 120Hz 25C
Failure Rate	P (0.1%/1000 Hrs)
ESR	2.4 Ohms (100kHz 25C)
Ripple Current	214 mA (rms, 100kHz 25C)
Leakage Current	1.4 uA (5min 25°C)
Testing and Reliability	Standard Testing Only

Statements of suitability for certain applications are based on our knowledge of typical operating conditions for such applications, but are not intended to constitute - and we specifically disclaim - any warranty concerning suitability for a specific customer application or use. This Information is intended for use only by customers who have the requisite experience and capability to determine the correct products for their application. Any technical advice inferred from this Information or otherwise provided by us with reference to the use of our products is given gratis, and we assume no obligation or liability for the advice given or results obtained.