

CWR11FB336KM

Aliases (T492D336K010MB)

T492 CWR11, Tantalum, MnO₂ Tantalum, Military/High Reliability, 33 uF, 10%, 10 VDC, SMD, MnO₂, Molded, Military Equivalent, M (1%/1000 Hrs), 1.1 Ohms, 7343, 3.1mm

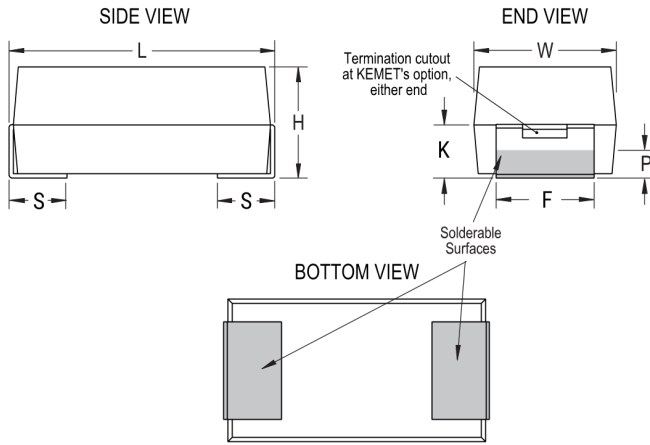

Click [here](#) for the 3D model.

Dimensions

Footprint	7343
L	7.3mm +/-0.3mm
W	4.3mm +/-0.3mm
H	2.8mm +/-0.3mm
T	0.13mm REF
S	1.3mm +/-0.3mm
F	2.4mm +/-0.1mm
B	0.5mm +/-0.15mm
E	3.5mm REF
G	3.5mm REF
K	1mm MIN
P	0.5mm MIN
R	1mm REF
X	0.1mm +/-0.1mm

Packaging Specifications

Packaging	T&R, 178mm
Packaging Quantity	500

General Information

Series	T492 CWR11
Dielectric	MnO ₂ Tantalum
Style	SMD Chip
Description	SMD, MnO ₂ , Molded, Military Equivalent
RoHS	Yes
Termination	Gold
Qualifications	MIL-PRF-55365/8, CWR11 Style
AEC-Q200	No
Typical Component Weight	412.33 mg
Notes	Note: When Option C Is Selected For Lead Material, Add An Additional 0.38mm To The Tolerances For "L", "W", "H", "K", "F" And "S".
MSL	1

Specifications

Capacitance	33 uF
Capacitance Tolerance	10%
Voltage DC	10 VDC (85C), 6.7 VDC (125C)
Temperature Range	-55/+125°C
Rated Temperature	85°C
Dissipation Factor	6% 120Hz 25C
Failure Rate	M (1%/1000 Hrs)
ESR	1.1 Ohms (100kHz 25C)
Ripple Current	369 mA (rms, 100kHz 25C)
Leakage Current	3.3 uA (5min 25°C)
Testing and Reliability	Standard Testing Only